



Transporter Dropside Van Specifications and Options

MY19

Commercial
Vehicles



Model – Single Cab Chassis	Code	TDI 340Nm SWB	TDI 340Nm LWB	TDI 450Nm SWB	TDI 450Nm LWB
Maximum Retail Price 7-Speed DSG		\$54,300 SFE1B7	\$57,300 SFL1B7	\$61,300 SFE1H7	\$64,300 SFL1H7
Maximum Retail Price 7-Speed DSG 4MOTION		-	-	\$67,300 SFE1H9	\$70,300 SFL1H9

Alternative Vehicle Configurations

Double Cab (5 or 6 seat configuration)	SFD***	-	\$1,000	-	\$1,000
Platform with Tray	ZP1	\$1,200	\$1,200	\$1,200	\$1,200

Technical Data

Power (kW) @ rpm		103 @ 3,500	103 @ 3,500	150 @ 4,000	150 @ 4,000
Torque (Nm) @ rpm		340 @ 1,750-2,500	340 @ 1,750-2,500	450 @ 1,400-2,400	450 @ 1,400-2,400
Cylinders		4 Cylinder, DOHC, 16 Valve	4 Cylinder, DOHC, 16 Valve	4 Cylinder, DOHC, 16 Valve	4 Cylinder, DOHC, 16 Valve
Fuel Type		Diesel, 80L tank	Diesel, 80L tank	Diesel, 80L tank	Diesel, 80L tank
Fuel Injection system		Common rail direct injection	Common rail direct injection	Common rail direct injection	Common rail direct injection
Front Suspension - Independent McPherson struts, sub frame with coil springs and gas filled dampers.		•	•	•	•
Rear Suspension - Semi trailing independent rear axle with coil springs and anti-roll bar		•	•	•	•
Rack and pinion power steering		•	•	•	•
Engine Upgrade Package <ul style="list-style-type: none"> 150kW/450Nm EU6 engine with Start Stop System and Ad Blue Technology Adaptive Cruise Control up 160km/h + Forward Collision Warning and Autonomous Emergency Braking 	SF*1H* + PAD	-	-	•	•

Weights and Dimensions

Gross vehicle mass 3,000kg	0WQ	•	•	•	•
Gross vehicle mass 3,200kg with harder springs and shocks (Increases payload by approx. 200kg).	PG1	\$2,800	\$2,800	\$2,800	\$2,800
Payload Single Cab chassis in kg, maximum. Manual (DSG)		1,423 (1,397)	1,408 (1,381)	1,347 (1,330)	1,332 (1,315)
Payload Double Cab chassis in kg, maximum. Manual (DSG)		-	1,382 (1,291)	-	1,242 (1,225)

*Maximum Retail Price (MRP) includes 15% GST and does not include on-road costs. Figures will change depending on model derivative and equipment fitted. All measurements listed are based on standard specification vehicles. The actual dimensions may differ slightly from the values stated here. Equipment may affect the unladen weight. A vehicles' actual payload, which is the difference between the gross vehicle weight and the unladen weight, can only be determined by weighing the individual vehicle. Specifications are subject to change without notice. Fuel consumption tested in accordance with EC directive 1999/94/EC and based on NEDC procedure unless stated otherwise. The fuel consumption is measured on European specification cars and may vary depending on specification, road condition, tyres and driving behaviour. Please refer to brochure for further information. Issued 20 December 2018.

Key: • (Standard) NCO (No Cost Option) - (Not available)



Transporter Dropside Van Specifications and Options

MY19

Commercial Vehicles

Model – Single Cab Chassis	Code	TDI 340Nm SWB	TDI 340Nm LWB	TDI 450Nm SWB	TDI 450Nm LWB
Payload Single Cab chassis 4MOTION in kg, maximum. (DSG)		-	-	(1,204)	(1,189)
Payload Double Cab chassis 4MOTION in kg, maximum. (DSG)		-	-	-	(1,099)
Un-laden weight (kg, minimum). Based on Manual standard spec single cab vehicle		1,577	1,592	1,653	1,668
Trailer load limit (kg). Braked, 12% gradient / Un-braked		2,500 / 750	2,500 / 750	2,500 / 750	2,500 / 750

Transporter Dropside Van with short wheelbase and single cab

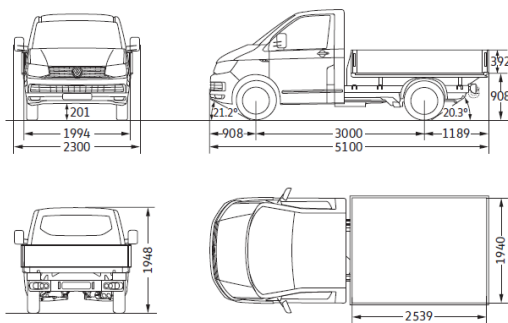

Transporter Dropside Van with long wheelbase and single cab

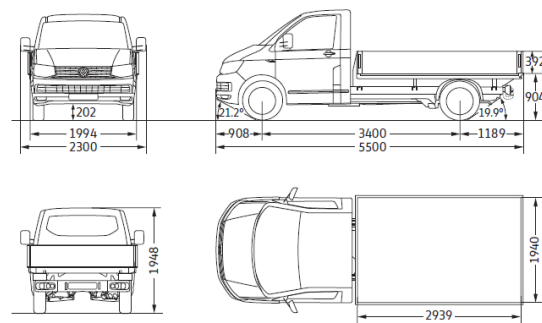

load area (m ²)	4.9
turning circle (m)	11.9

load area (m ²)	5
turning circle (m)	13

Transporter Dropside Van with long wheelbase and double cab

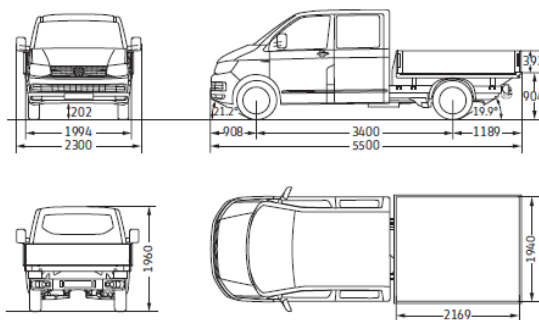

load area (m ²)	4.2
turning circle (m)	13.2

Transporter Chassis with short wheelbase and single cab

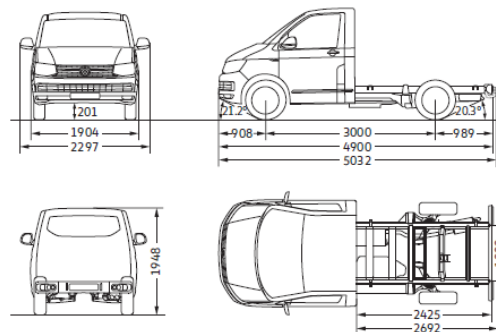

turning circle (m)	11.9
--------------------	------

*Maximum Retail Price (MRP) includes 15% GST and does not include on-road costs. Figures will change depending on model derivative and equipment fitted. All measurements listed are based on standard specification vehicles. The actual dimensions may differ slightly from the values stated here. Equipment may affect the unladen weight. A vehicles' actual payload, which is the difference between the gross vehicle weight and the unladen weight, can only be determined by weighing the individual vehicle. Specifications are subject to change without notice. Fuel consumption tested in accordance with EC directive 1999/94/EC and based on NEDC procedure unless stated otherwise. The fuel consumption is measured on European specification cars and may vary depending on specification, road condition, tyres and driving behaviour. Please refer to brochure for further information. Issued 20 December 2018.

Key: ● (Standard) NCO (No Cost Option) - (Not available)



Transporter Dropside Van Specifications and Options

MY19

Commercial Vehicles

Model – Single Cab Chassis	Code	TDI 340Nm SWB	TDI 340Nm LWB	TDI 450Nm SWB	TDI 450Nm LWB
----------------------------	------	---------------	---------------	---------------	---------------

Transporter Chassis with long wheelbase and single cab

Transporter Chassis with long wheelbase and double cab

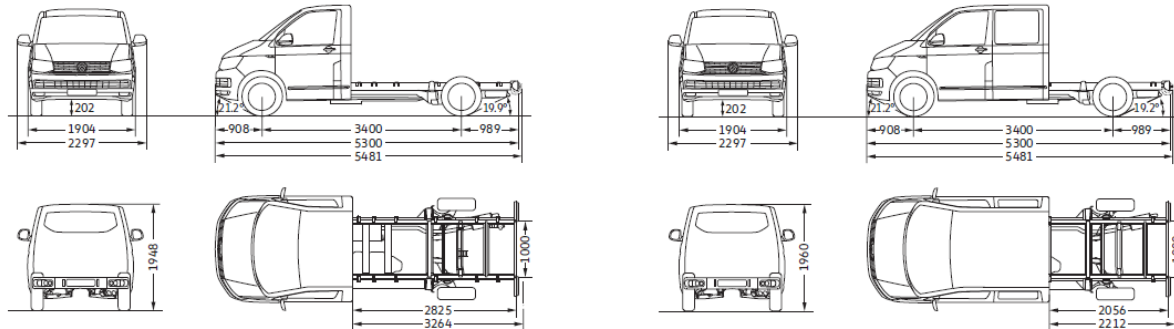

turning circle (m)

13.2

turning circle (m)

13

Fuel Consumption

Fuel consumption – combined (L/100km), from manual variant*	7.8*	7.8*	6.9	6.9
---	------	------	-----	-----

Safety and Security

Airbags, for driver and front passenger (with passenger airbag deactivation)	4UF	•	•	•	•
Airbags, driver and front passenger head and thorax (not available with bench seat)	4X3	\$750	\$750	\$750	\$750
Anti-theft alarm system with interior monitoring in cab, backup horn, and towing protection	7AQ	•	•	•	•
Automatic post-collision braking		•	•	•	•
Rest assist (Drowsiness detection)		•	•	•	•
Central locking system with interior release mechanism, SAFELOCK and radio remote control and 2 folding keys	Z4E / ZE2	•	•	•	•
Daytime driving lights	8K1	•	•	•	•
ESP (Electronic Stability Program) with hill hold function	1N1	•	•	•	•
Power steering with safety steering column (adjustable in height and length)	1AK	•	•	•	•
Vented disc brakes with ABS (anti-lock brake system), EDL (electronic diff lock, front), BA (brake assist) and anti-slip regulation (ASR)		•	•	•	•
3-point automatic seat belts in cab with height adjust, belt tensioners and belt reminder warning	4UF + 9P1	•	•	•	•

Wheels and Suspension

Steel wheels, 16" with 205/65 tyres	C1G	•	•	-	-
Steel wheels, 17" with 205/65 tyres		-	-	•	•
Alloy wheels, 16" Clayton alloys with 205/65 tyres	Z3E	\$1,200	\$1,200	\$1,200	\$1,200
Alloy wheels, 17" Devonport alloys with 235/55 tyres	Z3F	\$2,800	\$2,800	\$2,800	\$2,800
Full size light steel spare wheel with original equipment tyre.	1G2	•	•	•	•

*Maximum Retail Price (MRP) includes 15% GST and does not include on-road costs. Figures will change depending on model derivative and equipment fitted. All measurements listed are based on standard specification vehicles. The actual dimensions may differ slightly from the values stated here. Equipment may affect the unladen weight. A vehicles' actual payload, which is the difference between the gross vehicle weight and the unladen weight, can only be determined by weighing the individual vehicle. Specifications are subject to change without notice. Fuel consumption tested in accordance with EC directive 1999/94/EC and based on NEDC procedure unless stated otherwise. The fuel consumption is measured on European specification cars and may vary depending on specification, road condition, tyres and driving behaviour. Please refer to brochure for further information. Issued 20 December 2018.

Key: • (Standard) NCO (No Cost Option) - (Not available)



Transporter Dropside Van Specifications and Options

MY19

Commercial
Vehicles

Model – Single Cab Chassis	Code	TDI 340Nm SWB	TDI 340Nm LWB	TDI 450Nm SWB	TDI 450Nm LWB
Suspension – Heavy duty stabilisers front and rear. Lower lateral tilt of vehicle/ increased roll resistance, reduced side wind sensitivity. Only for vehicles with 3,000kg GVM	2MF	\$600	\$600	\$600	\$600
Suspension – reinforced rear. For loading of rear axle up to max. axle load. Only for vehicles with 3,000kg GVM.	2MK	\$400	\$400	\$400	\$400

Functional Equipment

LED headlamps and tail lamps with separate LED daytime running lights incl. automatic headlight-range adjustment dynamic (self-adjusting while driving), dimmable dash illumination, headlamp washer system with heated washer nozzles in front and washer fluid level indicator	PXE	\$2,500	\$2,500	\$2,500	\$2,500
Climatic semi-automatic air conditioning system in cab	9AP + KK1	•	•	•	•
Cruise control	8T1	•	•	•	•
Leather-wrapped multi-function steering wheel with radio and cell phone controls	ZE7	•	•	•	•
Dash mounted gearshift lever	ZE7	•	•	•	•
Electric front windows, with anti-trap function and electrically adjustable/heated side door mirrors	ZE8	•	•	•	•
Instrument cluster – digital clock, gear display, odometer, trip odometer, speedometer, consumption, fuel gauge, temp gauge for coolant	U5A	•	•	•	•
Mechanical differential lock, on rear axle (available on 4MOTION only)	1Y4	\$1,500	\$1,500	\$1,500	\$1,500
Multi-function display, 'Plus'; shows route time, average speed, actual speed, oil temp, speed warning, travel time, actual fuel consumption, average fuel consumption and range	ZEN	•	•	•	•
Steering wheel with height and reach adjustment	1N1	•	•	•	•
Windshield wiper, two speed, with variable intermittent control	8N1	•	•	•	•
Colour coded front bumpers with body coloured mirror housings and door handles	PL4	\$1,300	\$1,300	\$1,300	\$1,300
Front fog lights and cornering lamp	8WH	\$650	\$650	\$650	\$650
Mud flaps, front and rear	6N2	\$350	\$350	\$350	\$350
LED number plate lighting		•	•	•	•
Paint – metallic or pearl effect		\$1,600	\$1,600	\$1,600	\$1,600
Tow bar preparation	1D7	•	•	•	•
Rear tray with aluminium sides (folding), safety latches and rear step	ZP1	•	•	•	•

Interior Features

Comfort Package (dimmable dash, two-tone horn, dual vanity mirrors, sunglasses holder, additional noise insulation in the cab, grab handle on passenger A pillar and socket in front)	ZA1	\$550	\$550	\$550	\$550
Roof interior trim in cab as comfort moulded headlining.	5CG	•	•	•	•

*Maximum Retail Price (MRP) includes 15% GST and does not include on-road costs. Figures will change depending on model derivative and equipment fitted. All measurements listed are based on standard specification vehicles. The actual dimensions may differ slightly from the values stated here. Equipment may affect the unladen weight. A vehicles' actual payload, which is the difference between the gross vehicle weight and the unladen weight, can only be determined by weighing the individual vehicle. Specifications are subject to change without notice. Fuel consumption tested in accordance with EC directive 1999/94/EC and based on NEDC procedure unless stated otherwise. The fuel consumption is measured on European specification cars and may vary depending on specification, road condition, tyres and driving behaviour. Please refer to brochure for further information. Issued 20 December 2018.

Key: • (Standard) NCO (No Cost Option) - (Not available)



Transporter Dropside Van Specifications and Options

MY19

Commercial
Vehicles

Model – Single Cab Chassis	Code	TDI 340Nm SWB	TDI 340Nm LWB	TDI 450Nm SWB	TDI 450Nm LWB
Driver seat with height adjust and lumbar support	7P6	•	•	•	•
Front passenger bench seat in cab	3TJ	•	•	•	•
Single passenger seat in cab	-3TJ	NCO	NCO	NCO	NCO
Seat covering – ‘Austin’ Titanium black / Moon rock cloth upholstery	N1L	•	•	•	•
3-Seater bench in the rear for Double Cab	3UH	•	•	•	•

Multimedia

Provision for mobile phone with Bluetooth (Hands Free Profile)	9ZX	•	•	•	•
Radio “Composition Media with 6.33” TFT colour touchscreen display with MP3 compatible CD player, 4 loud speakers, SD card slot, USB port and AUX-IN socket	Z16	•	•	•	•
Radio “Discover Media” with 6.33” TFT colour touchscreen display, Navigation with maps stored on SD card, MP3 compatible CD player, 4 loud speakers, 2 x SD card slots, USB port, AUX-IN socket, Connectivity package including 1 year mapcare	Z17	\$1,050	\$1,050	\$1,050	\$1,050
App-Connect (Displays and controls smart phone via touchscreen)	9WT	•	•	•	•

Warranty

3 year / 100,000 km mechanical warranty		•	•	•	•
3 year paint warranty		•	•	•	•
12 year anti-corrosion warranty		•	•	•	•
3 year Volkswagen Roadside Assistance		•	•	•	•
Up to 40,000 km (or every two years) oil service intervals		•	•	•	•

Packages

Three-way tipper with cab guard for cab rear panel (Engineering cert. as per §13 EG-FGV, entry in registration certificate, part I required for registration, Second battery with cut-off relay, maintenance-free)	YGS YAA SR3 8FB S27	\$6,500 (Single cab)	\$6,500 (Double Cab)	\$6,500 (Single cab)	\$6,500 (Double Cab)
			\$8,500 (Single Cab)		\$8,500 (Single Cab)

*Maximum Retail Price (MRP) includes 15% GST and does not include on-road costs. Figures will change depending on model derivative and equipment fitted. All measurements listed are based on standard specification vehicles. The actual dimensions may differ slightly from the values stated here. Equipment may affect the unladen weight. A vehicles’ actual payload, which is the difference between the gross vehicle weight and the unladen weight, can only be determined by weighing the individual vehicle. Specifications are subject to change without notice. Fuel consumption tested in accordance with EC directive 1999/94/EC and based on NEDC procedure unless stated otherwise. The fuel consumption is measured on European specification cars and may vary depending on specification, road condition, tyres and driving behaviour. Please refer to brochure for further information. Issued 20 December 2018.

Key: • (Standard) NCO (No Cost Option) - (Not available)



Commercial
Vehicles

Transporter Dropside Van Specifications and Options

MY19

3-Way Tipper – Fact Sheet



Three-way tipper with cab guard for cab rear panel

The VW 3-Way tipper is developed and engineered by a VW Premium Partner in Germany. The engineering and manufacturing is completed to VW Standards. The Tipper is available for Single Cab and Double Cab Transporters and also for Amarok and Crafter. Further to that, it is available in Manual and DSG and 4MOTION and 2WD. A cab guard protects the passenger and driver cabin during operation.

The tipper has a second battery (maintenance free) and a cutoff relay, which allows tipping without ignition on and hence no influence on the main vehicle battery. The tray is made of Aluminum and the frame is high quality welded and completed in hot-dip galvanization for highest possible protection and a long-term rust protection. The



*Maximum Retail Price (MRP) includes 15% GST and does not include on-road costs. Figures will change depending on model derivative and equipment fitted. All measurements listed are based on standard specification vehicles. The actual dimensions may differ slightly from the values stated here. Equipment may affect the unladen weight. A vehicles' actual payload, which is the difference between the gross vehicle weight and the unladen weight, can only be determined by weighing the individual vehicle. Specifications are subject to change without notice. Fuel consumption tested in accordance with EC directive 1999/94/EC and based on NEDC procedure unless stated otherwise. The fuel consumption is measured on European specification cars and may vary depending on specification, road condition, tyres and driving behaviour. Please refer to brochure for further information. Issued 20 December 2018.

Key: • (Standard) NCO (No Cost Option) - (Not available)



Commercial
Vehicles

Transporter Dropside Van Specifications and Options

MY19

floor of the tray is an original Finnish screen print with special surface coating. There are 6 lashing rings in the tray which can be used for securing goods. The maximum force for securing goods with the lashing rings is 400kg with a minimum angle of 30 degrees. The loading is possible from both sides and the rear as all 3 tray-sides fold down with an angle lever lock on the left and right. The entire electric and hydraulic installation is waterproof and done under German Quality Standards. The Product is certified under European Standards and also TÜV-tested (cert. as per §13 EG-FGV, entry in registration certificate, Test number LS 100863 Safety Loads).



The tipping force is generated by a BOSCH Rexroth hydraulic pump. The hydraulic unit can lift the payload, which is defined by the model. Hence there is no lifting limitation by the tipper itself. The fixing point is ball bearing stamp with a grease nipple. The hydraulic fluid container is located directly next to the pump and supplies the fluid to the pump and cylinder.



The fenders are available in plastic and steel. The tipper is operated by remote control in the driver's cab and is connected to a 1.5m cable allowing use outside the cab. Further to that the remote control can be fixed with two magnets. The tipper has a maximum angle of 50 degrees. At 50 degrees it will stop automatically. For safety reasons, a sound is generated after reaching 30 degrees.



The standard tipping function is rear tipping. This means two bolts have to be fixed in the rear frame in order to allow the rear tipping. For tipping on the side, one bolt has to be changed to the front left or right side in order to fix the side tray and allow the sideward tipping.

IMPORTANT:

Never use the tipping function without bolts or with only one bolt. It is crucial that both bolts are always used during tipping.

*Maximum Retail Price (MRP) includes 15% GST and does not include on-road costs. Figures will change depending on model derivative and equipment fitted. All measurements listed are based on standard specification vehicles. The actual dimensions may differ slightly from the values stated here. Equipment may affect the unladen weight. A vehicles' actual payload, which is the difference between the gross vehicle weight and the unladen weight, can only be determined by weighing the individual vehicle. Specifications are subject to change without notice. Fuel consumption tested in accordance with EC directive 1999/94/EC and based on NEDC procedure unless stated otherwise. The fuel consumption is measured on European specification cars and may vary depending on specification, road condition, tyres and driving behaviour. Please refer to brochure for further information. Issued 20 December 2018.

Key: • (Standard) NCO (No Cost Option) - (Not available)